

OFFICE SPACE FOR LEASE

GILBERT TOWN SQUARE

1090 AND 1094 SOUTH GILBERT ROAD | GILBERT, ARIZONA 85296



FEATURES:

- Gilbert Town Square is a mixed-use project offering a blend of professional employment, dining, shopping and entertainment
- High quality architectural controls on exterior finishing for efficient flow
- Parking: 5.0/1,000
- Rental Rate: \$22.00 Full Service

FOR MORE INFORMATION CONTACT:

Jamie Swirtz

Associate
602.735.5630
jamie.swirtz@cbre.com

Jerry Roberts

Executive Vice President
602.735.5528
jerry.roberts@cbre.com

CBRE

1090 SOUTH GILBERT ROAD

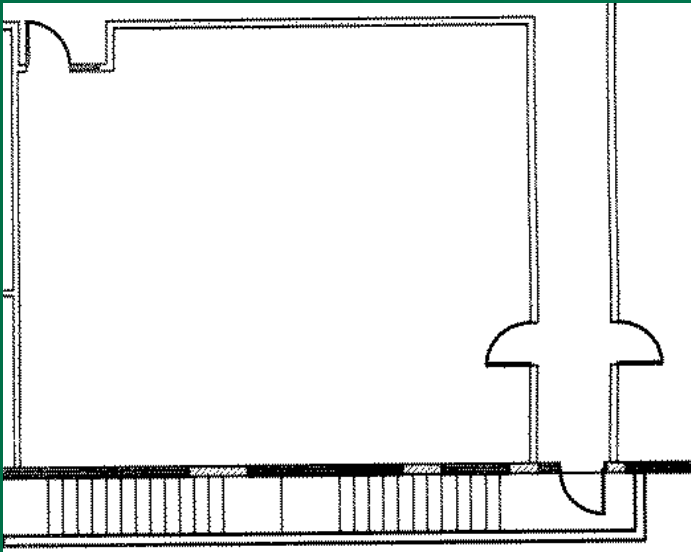

SUITE 206 - ±1,138 SF

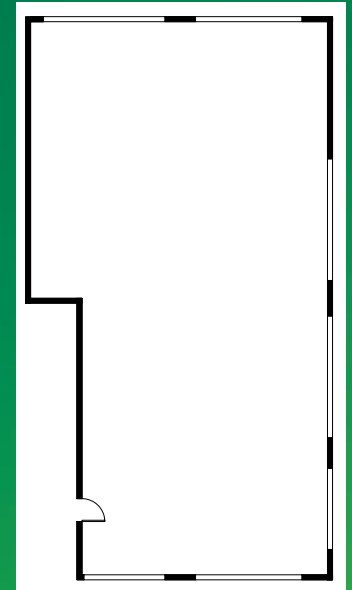

SUITE 209 - ±3,699 SF

1094 SOUTH GILBERT ROAD

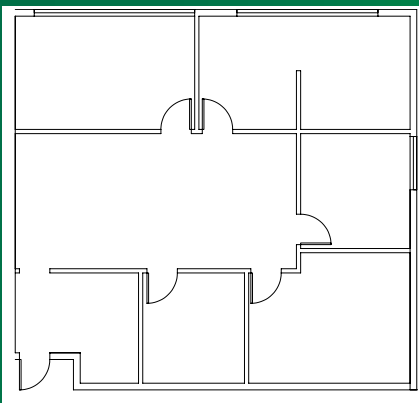

SUITE 201 - ±1,566 SF

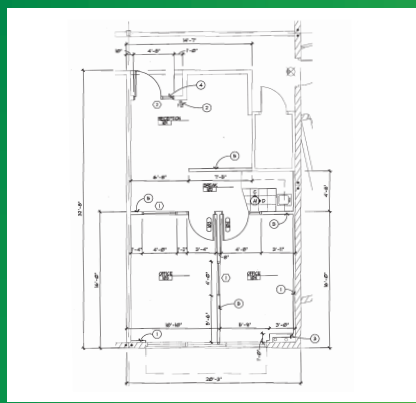

SUITE 213 - ±671 SF

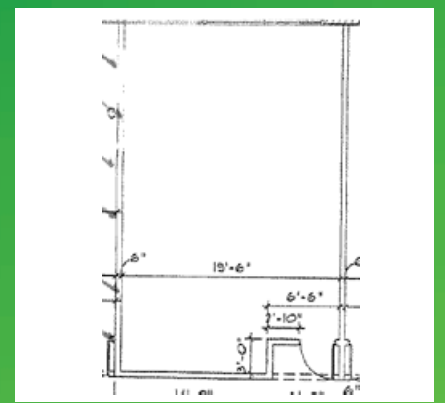

SUITE 214 - ±602 SF

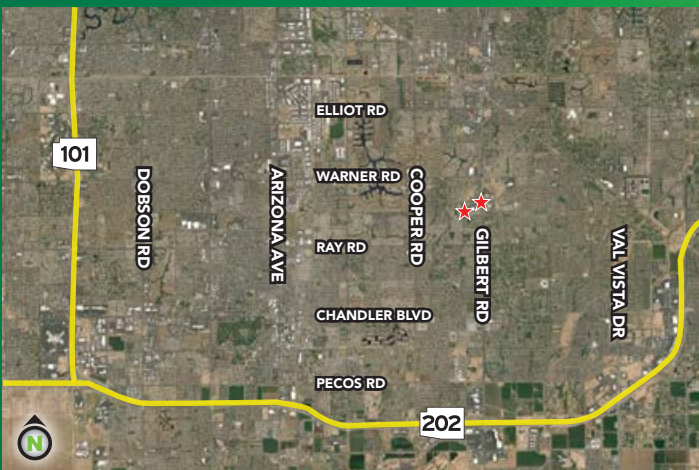

Floor plans and map not to scale

FOR MORE INFORMATION CONTACT:

Jamie Swirtz

Associate
602.735.5630
jamie.swirtz@cbre.com

Jerry Roberts

Executive Vice President
602.735.5528
jerry.roberts@cbre.com

CBRE